

SenSmart 7000 Series

"The Art of Gas Detection" - Built with our Proven WaveCast Transmitter



Non-metallic Poly "PY" model



Aluminum "AL" XP model



Stainless "SS" model with Dual Sensor

The battery -powered **SenSmart 7000** wireless gas detector, with ultra-low power design and easy to use features, provides the most advanced, economical and reliable true wireless toxic and combustible gas detection solution. The **SenSmart 7000** is compatible with all RC System's toxic sensors, including hydrogen sulfide, carbon dioxide, oxygen, hydrogen cyanide and many others. In addition, the **SenSmart 7000** also supports the new low-power infrared sensor for hydrocarbon combustibles or carbon dioxide.

FEATURES HIGHLIGHT

- CSA Certified for Class 1, Division 2 hazardous locations
- D-cell lithium battery powered for up to 9 months Toxic/Oxygen and 6 months LEL operation
- Available for both 900Mhz and 2.4Ghz
- Frequency-Hopping Spread Spectrum (FHSS) technology
- Typical > 1 mile range with local dipole antenna (900Mhz)
- Detected gas data transmits on six second intervals
- Supports Single or dual sensor
- Graphic display shows values, units, trend graph, alarm levels
- Power ON / Power OFF using magnetic wand only
- Non-intrusive, user-prompted calibration procedure
- Transmits all setup information to Wireless Receiver
- Security settings to lock critical parameters
- Auto-recognition of Smart Sensors uploads calibration data and more
- Fault supervision circuitry detects failed sensor and transmits warning
- Setup in hazardous area requires only simple magnetic wand
- Magnetic mount option available
- Three adjustable independent alarm levels per sensor
- 5 LEDs indicate alarms and communication status

SPECIFICATIONS

Power Supply	Replaceable internal D-cell lithium battery; 9 months Toxic/Oxygen and 6 months LEL operation
Display	Display 64 x 128 pixel LCD with 30-minute trend, bargraph and engineering units display.
Input	Single or dual channel input from toxic or infrared hydrocarbon combustible sensors
Standard Output	License-free 900MHz or 2.4Ghz frequency-hopping spread spectrum (FHSS) wireless modem with data encryption 900MHz power adjustable from 10mW to 1.0 watt/0-30dBm 2.4GHz output set at 125mW/21dB,
Receiver Sensitivity	900 MHz -100dBm typical 2.4 GHz -98dBm typical
Temp	-25°C to +55°C (see sensor limitations)
Housing	Aluminum with epoxy paint standard; Optional #316 stainless steel, Optional UI94 Poly Black Plastic Enclosure
Dimensions	(Aluminum) Width 5.4" (137 mm), Height 8" (203 mm), Depth 5" (127 mm) Shipping weight 6.5 pounds (3 kg) (Poly) Width 5" (127 mm), Height 7" (178 mm), Depth 4" (101 mm) Shipping weight 3 pounds (2 kg)
Approvals	FCC 15.247 & Industry Canada (IC), CSA Certified for Class 1, Division 2 hazardous locations
Performance	2.4GHz frequency range: 2400 - 2483.5 MHz with 42 hops 2.4GHz indoor/urban range: Up to 1500 feet with 7dBi collinear antenna 2.4GHz outdoor RF LOS range: Up to two miles with high-gain antenna 900MHz frequency range: 902 - 928 MHz with 50 hops 900MHz indoor/urban range: Up to 3000 feet with 2dBi dipole antenna 900MHz outdoor RF LOS range: Up to five miles with high-gain antenna

Poly Housing

Single Sensor Aluminum Housing

Dual Sensor Aluminum Housing

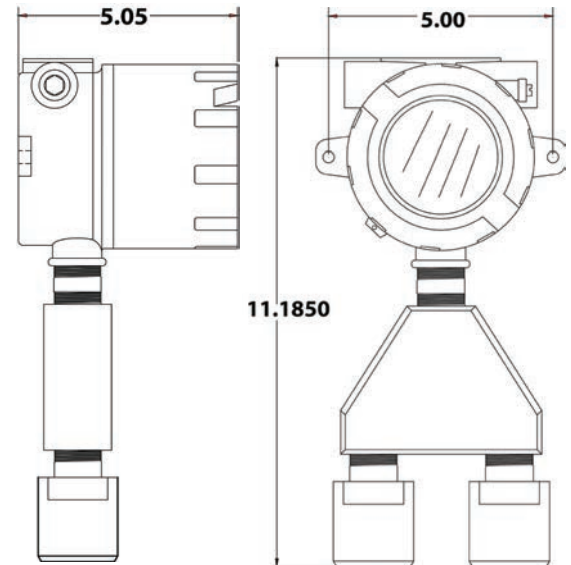
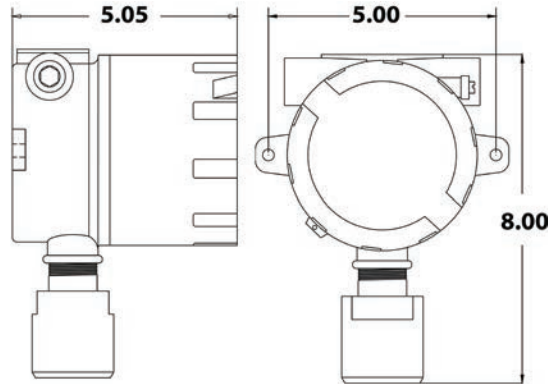
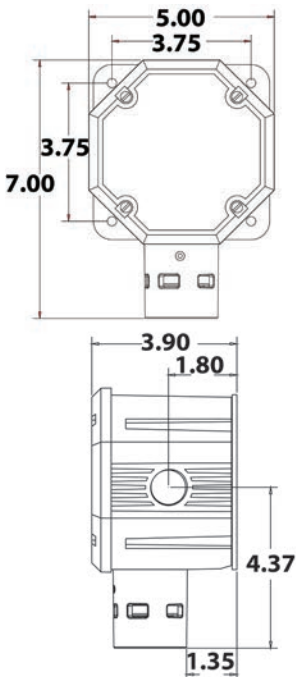

ALL DIMENSIONS IN INCHES

Represented by:

C A Briggs Company

622 Mary Street; Suite 101

Warminster, PA 18974

Phone: 267-673-8117 - 800-352-6265

Fax: 267-673-8118

Sales@cabriggs.com - www.cabriggs.com



8621 Highway 6, Hitchcock, TX 77563

Tel: (409) 986-9800 • Fax: (409) 986-9880

www.rcsystemsco.com